

Clamp Attachment

Used for gripping loads by the diameter or circumference such as reels, drums, barrels etc and rotating to any position through 360° deg.

For application outside of the standard range the company provides a full bespoke design service offering solutions for most applications.

Packline's range of attachments are fully interchangeable and can be easily fixed or removed from any model of Compac fitted with the unique quick release system.

Overview:-

- Available as Manual or Geared Rotation
- Loads capacity up to 300kg
- Fitted with Rotating rubberised rollers jaws to provide maximum grip and assist alignment
- Suitable for load diameters of up to 850mm as standard
- Built in Slip Torque mechanism to ensure correct gripping pressure is applied preventing over tightening and damage to load
- Constructed mainly from anodized aluminium, Stainless Steel and Brass and Acetal.



Specification Sheet for Clamp Attachment

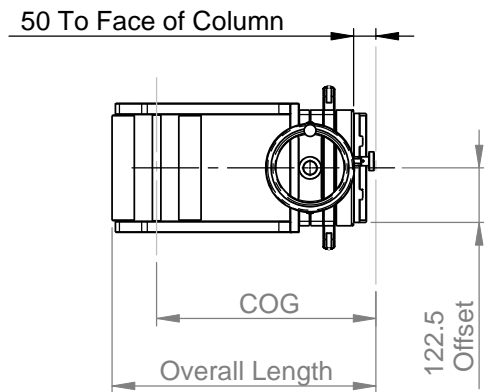
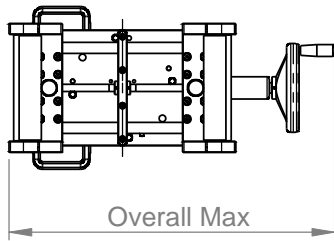
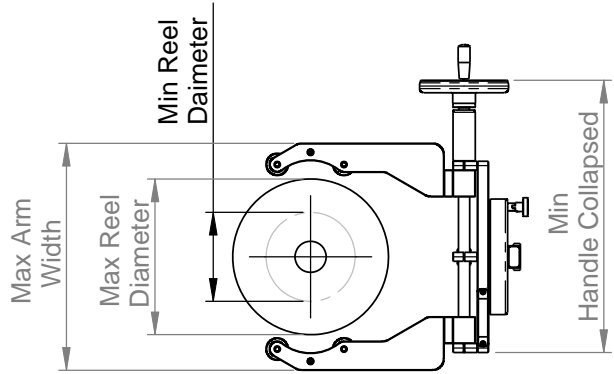
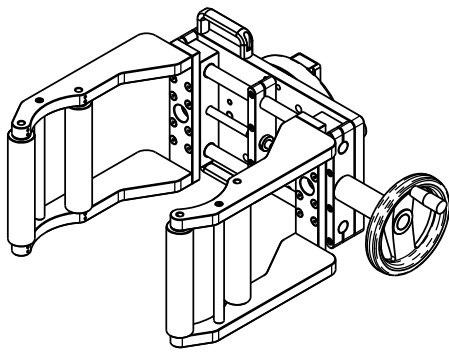

	Description	Load Centre	Max. SWL on Compac Model;			Reel Diameter		Reel Length		Mass
			C60	C150	C300	Min.	Max.	Min.	Max.	
CL4100-5	SD/200/350/Rollers	493mm	18kg	108kg	200kg	200mm	350mm	300mm	42kg	
CL4101-5	SD/350/520/Rollers	503mm	14kg	104kg	200kg	350mm	520mm	300mm	46kg	
CL4102-5	SD/200/550/Rollers	493mm	-	100kg	200kg	200mm	550mm	300mm	51kg	
CL4110-5	HD/250/650/Rollers	548mm	-	78kg	230kg	250mm	650mm	300mm	72kg	
CL4111-5	HD/450/850/Rollers	658mm	-	70kg	205kg	450mm	850mm	300mm	81kg	

Based on Clamps with LOC005
Same distance in horizontal and Vertical Orientations

	Min. Lift Height		Max. Lift Height	
	C60/150	C300	C60/150	C300
50C	293.5mm	347.5mm	1780.5mm	1763.5mm
100C	344.5mm	398.5mm	1831.5mm	1814.5mm
85P	288.5mm	352.5mm	1775.5mm	1758.5mm
85R	288.5mm	352.5mm	1775.5mm	1758.5mm

