

Rotary Tray Attachment

The Rotary Tray Attachment has been designed to support loads and allow them to rotate in the horizontal plane through 360° suitable for lifting and positioning loads such as Reels, Drums, Sacks, etc.

Constructed from Stainless Steel the attachment is suitable for hygienic and clean room applications

Comprehensive Range

Available in a wide range of sizes as standard and backed up by a full bespoke design service ensuring the right solution can be provided for most applications.

Fully Interchangeable

Packline's full range of attachments are fully interchangeable and can be easily fixed or removed from any model of Compac fitted with the unique quick release system.

This quick release system enables one Compac to be used with multiple attachments providing an economical solution to a range of applications.

CE Marked and Fully Tested

Every design is fully tested, CE marked, supported by a detailed technical file meeting the latest legislation and health & safety directives.



Specification for Rotating Tray Attachment

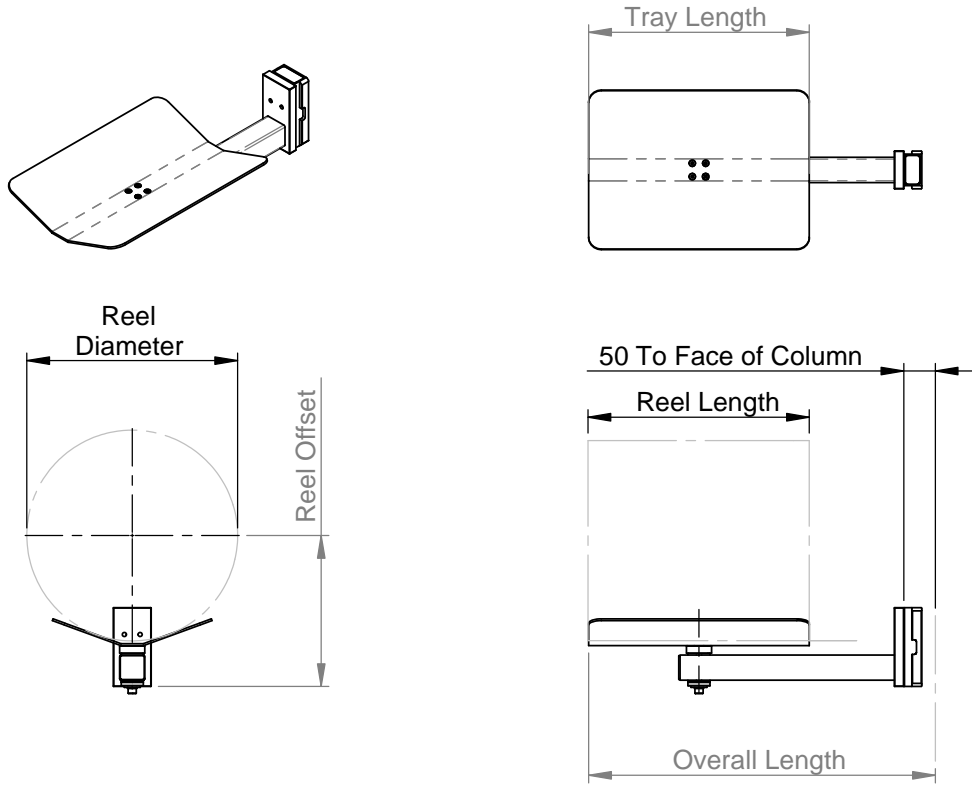

HD Version

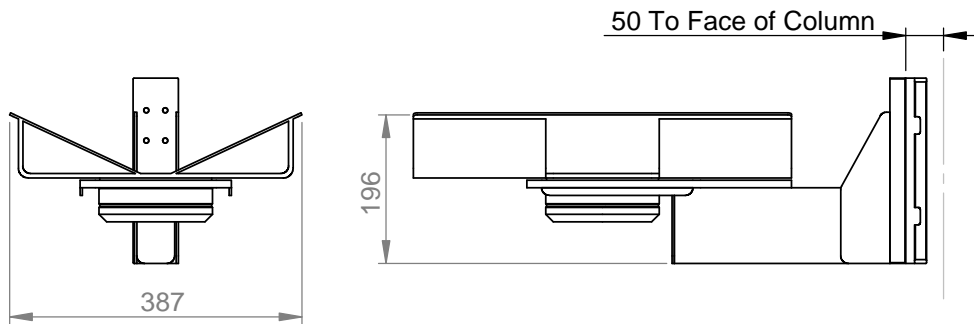

	Description	Max. SWL	Load Centre	Max. SWL on Compac Model;			Reel Diameter		Attachment
				C60	C150	C300	Min.	Max.	Mass
RT2129-1	310	75kg	375mm	56kg	75kg	75kg	-	450	3.8kg
RT3000-1	350	75kg	415mm	56kg	75kg	75kg	-	450	4kg
RT5111-18	690/HD	300kg	690mm	26kg	80kg	190kg/500L 215kg/600L	-	1000	34kg
RT5139-18	450/HD	300kg	450mm	28kg	120kg	265kg/500L 270kg/600L	-	1000	32kg
RT5140-18	550/HD	300kg	550mm	28kg	110kg	245kg/500L 265kg/600L	-	1000	33kg

Minimum and Maximum Lift Height will depend of reel diameter and therefore must be accessed for each individual application