



# STAINLESS STEEL

HIGHEST QUALITY STAINLESS STEEL



TRANSPORT

LIFT AND STACK

ROTATE AND TURN

CUSTOMISED

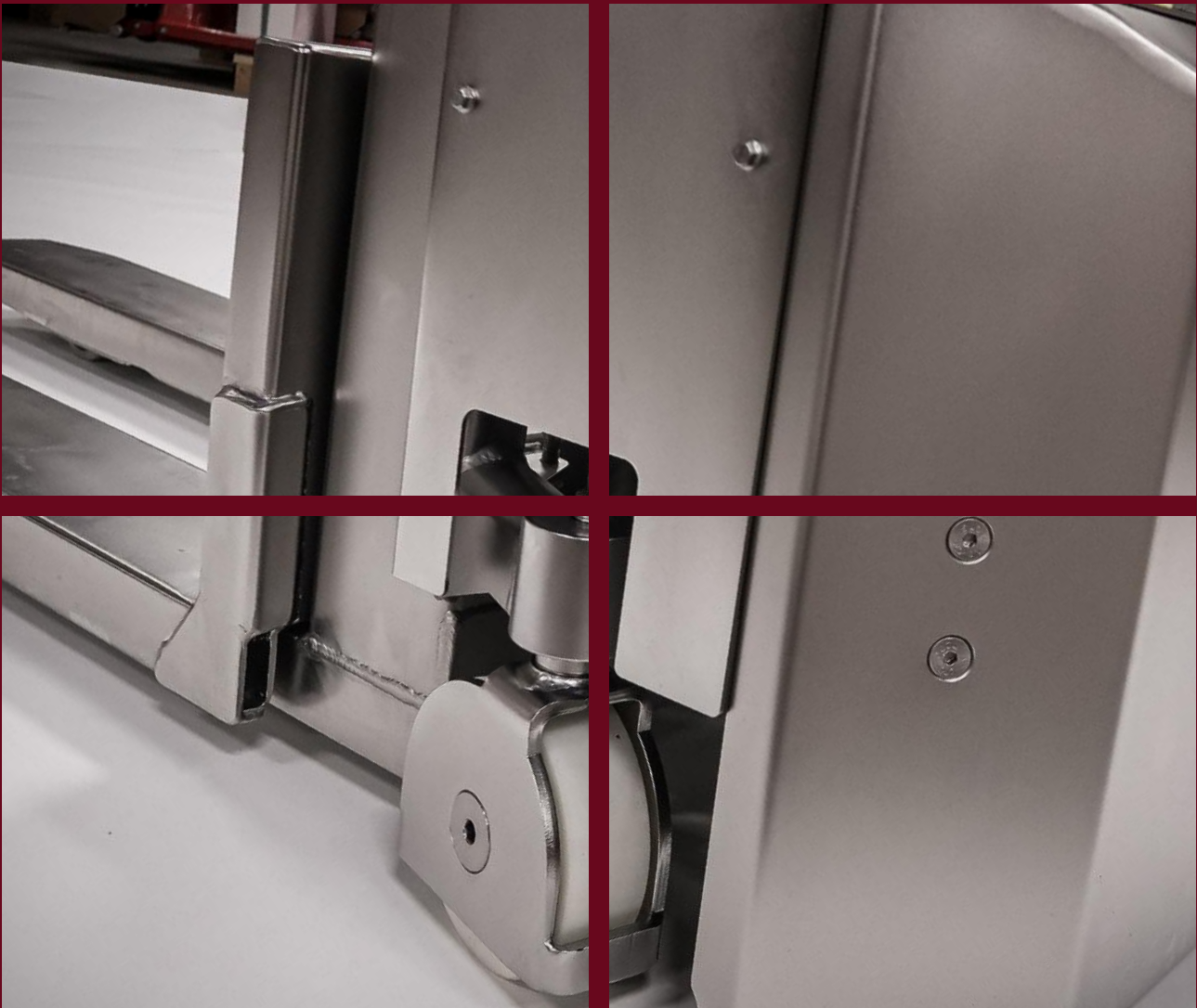

## The best quality stainless steel products on the market!

**Quality can never be a compromise - we value our customers' preference for our stainless steel products very much, and we are determined to deliver same high quality every time.**

Stainless steel products operate in different environments and must meet different requirements from our customers.

The nature of your environment determines which features and specifications your stainless steel equipment should have.

No matter what product you are looking for, we always offer the **best design** and **highest quality** on the market.

See our detailed specifications on page 9 and pages 10-23 for

further information about levels and constructions of our stainless steels products.

Our stainless steel products have a **long operating life** and are **easy to maintain**. These are very valued features for our customers, as the investment pays back quickly and you can access the spare parts easily and provide onsite maintenance.

The **compact construction** of the products makes them easy to operate and manoeuvre in confined areas. Hence, you get

powerful, reliable and efficient equipment that does not take up a lot of space.

If you have special requests, we also **customise** our solutions to match your specific situation.

In this brochure you will find information about different versions of stainless steel equipment - your choice of product should always be based on your specific situation and requirements.

Smooth electropolished surfaces

Highest quality acid-resistant AISI 316L steel for fork chassis

Closed design for easy cleaning and to avoid bacterial contamination

Oil for low operation temperatures  
Compact constructions

Constructed specifically to meet high hygienic standards

Option for pharma finish



White tandem wheels for a high level of hygiene



Elegant design with rounded corners and closed forks to protect surroundings and operator



Waterproof stainless steel cover

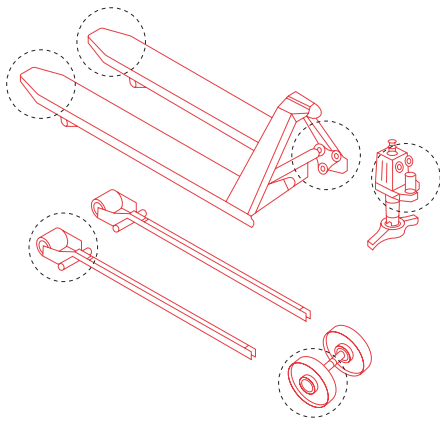

## The design

A good hygienic design minimises the risk of growth and contamination of microorganisms. Therefore, we construct our products from the bottom to meet the criteria for high hygiene, easy cleaning and easy maintenance:

- High quality stainless steel (AISI 304L/316L)
- Closed truck elements
- Smooth electropolished surfaces
- All parts are extra fastened and include a minimum of non-detectable material



## Cleaning

Your working environment determines which product you need.

All our stainless steel products have smooth and shiny surfaces with no burrs or pointy elements. This ensure easy cleaning/wiping without risks for scratches and bacterial infection. In addition, there are no particles or flakes of paints on the products.

- If you need to clean the product more aggressively than by wiping it off with a cloth, you need to look for those products, which tolerates wet and aggressive environments.
- If you work in dry and sanitary environments, you only need to clean the products gently with a dry or moist cloth. All our products tolerate disinfectants and you can provide extra cleansing treatments with cleanroom disinfectant/sterilant liquids like Spor-Klenz.
- For anti-static or explosive atmospheres, you need to look for our manual explosion proof products. These are available within pallet trucks, highlifters and stackers.

Please refer to the overview on page 9 for further information about cleaning and environment.



## Pharma finish?

When you operate in dry environments, it is crucial that you are able to keep the surroundings clean without using water or chemicals. Pharma Finish helps you to ensure a high level of cleanability and to eliminate bacterial contamination.

Pharma Finish means that we make an extra check, polish and finish of our stainless products. We have extra focus on quality, design and finish during the whole manufacturing process. This concerns both welding, deburring and polishing of all sharp and pointed parts.

# When hygiene matters



“In all situations where hygiene and cleanliness are top priorities, our pharmaceutical customers always use stainless steel equipment from Logitrans - because when it comes to hygiene in highly sensitive areas, such as the manufacture of medicines, we do not accept any compromises.

Only stainless steel with fine and straight surfaces prevents settlements of microorganisms, bacteria and viruses. The stainless steel lifting equipment from Logitrans is robust, durable and functional. This minimises production downtime in clean rooms.”

*Managing Director, Alexander Klohk, Industribedarf KLOHK GmbH*



## Rotator Inox

Our fully powered rotator in stainless steel is a perfect solution for customers working in dry environments with high hygienic standards.

The ergonomic benefits of fully powered rotation prevent unnecessary strains on the operator - the Rotator can lift and rotate large items such as crates and boxes, which allows the operator to reach the content or empty the container without stretching, bending or straining his back.

The Rotator is constructed to meet the high hygienic requirements of e.g. pharmaceutical or food processing environments, as the turning carriage, battery box, box holders and handle are made of stainless steel, whereas the chassis is chromated.



## Customised stacker for a longtime customer

The large pharmaceutical company, CSL Behring, uses these stainless units to ensure good ergonomic working conditions for their employees.

These customised stackers with level control operate in clean rooms, where they lift pallets to a proper ergonomic working height and automatically adjust the height as they load/unload.

A valued and loyal customer since 1993.



## Multi drum turner Inox

A big cosmetics company in Belgium uses our stainless steel multi drum turner for emptying drums of 200 liter in very narrow spaces.

It was important for the customer that the construction was very compact and customised with shorter legs to be able to pick up the drums from the floor.

All steel elements are constructed in either AISI 304L or AISI 316L stainless steel, only exception is the cylinder, which is chromitted.

The product has all functionalities and benefits of a standard MDT.

# When customisation matters



“We have chosen Logitrans products for our medicine production, because they are ergonomically correct, because they take up very little space and because Logitrans has tailored a product for our production. The goods on the pallets are not damaged, as a special valve ensures that the forks, for example, stop quietly and precisely, it is by far, the best we have seen on the market.”

*Customer in the pharmaceutical industry*



**PANTHER INOX PLUS (PIP)**



**PANTHER INOX (PI)**



**PANTHER INOX  
(EXPLOSION PROOF)**



**MANUAL HIGHLIFTER  
INOX PLUS (HLIP)**



**ELECTRIC HIGHLIFTER  
INOX PLUS (EHL 1004)**



**MANUAL HIGHLIFTER INOX  
(EHL 1004) + (EXPLOSION PROOF)**



**ELECTRIC HIGHLIFTER  
INOX (EHL 1004)**



**MANUAL STACKER INOX +  
STRADDLE (HS/HSS 1000)**



**ELECTRIC STACKER INOX +  
STRADDLE (EHS/EHSS 1000)**



**MANUAL STACKER  
(EXPLOSION PROOF)**



**ROTATOR INOX + STRADDLE  
(SELF/SELFRS 1003)**



**LOGITILT INOX + STRADDLE  
(LTI/LTIS)**



# In which environment do you want to use the product?

Stainless steel products operate in different environments and must meet different requirements from our customers. What is your environment?

Environments	Examples industries	Logitrans products managing these environments			
<p><b>Very aggressive, wet environments</b> The product is wet due to liquid dissolutions (acid, base or brine) almost all the time.</p> <p><b>Cleaning</b> Aggressive cleaning. Cleaning with foam (acid or base) (washing) PH in the cleaning material is much lower or much higher than 7.0</p>	<p><b>Preparation processes in</b> Food and fish industries Slaughterhouses Dairies</p>				
<p><b>Aggressive, wet environments</b> The product is wet and moist most of the time.</p> <p><b>Cleaning</b> Aggressive cleaning. Cleaning with foam (acid or base) (washing). PH in the cleaning material is much lower or much higher than 7.0</p>	<p><b>Production processes in</b> Food industry Slaughterhouses Dairies</p>				
<p><b>Clean, moist environments</b> The product is moist only occasionally.</p> <p><b>Cleaning</b> Gentle cleaning when wiping or washing (only forks). Neutral water (PH7), when necessary with gentle cleaning materials.</p>	<p>Pharmaceutical industry Food industry</p>				
<p><b>Clean, dry environments</b> The product is dry all the time.</p> <p><b>Cleaning</b> Cleaning the products with dry or moist cloth.</p>	<p>Pharmaceutical Packaging in the food industry</p>	<p>All Logitrans stainless products</p>	<p>Panther Inox, HS/EHS Inox HL/EHL Inox, Logitilt Inox Stainless fully-powered products</p>	<p>EHL Inox Plus HL Inox Plus</p>	<p>Panther Inox Plus</p>







## Key sketches Construction and material

Our high quality stainless steel products are constructed of different parts and elements.

Not all steel parts are stainless or acid resistant material, but instead chromated. This type of surface treatment provides a protective chemical coating of chromate, which strengthens the quality of the steel and guarantees high resistance towards water, salt or chemicals.

The colours yellow and red in the table below mark the chromated material. (Black and silver zinc/iron passivation with sealer).

The drawing below is an example of our key sketches, which you can find together with the spec sheets for the individual products on our website.

						
<b>Acid-resistant steel</b>	<b>Stainless steel</b>	<b>Zinc-iron black passivating + sealer*</b>	<b>Zinc-iron silver passivating + sealer*</b>	<b>Rubber sealed bearings</b>	<b>Bronze</b>	<b>Painted 130-150 µm</b>
EN 14404 (AISI 316L) EN 14460 (AISI 329)	EN 14305 (AISI 303) EN 14301 (AISI 304)	Fe//ZnFeX//Fn//T2	Fe//ZnFeX//Cn//T2			

\*chromated

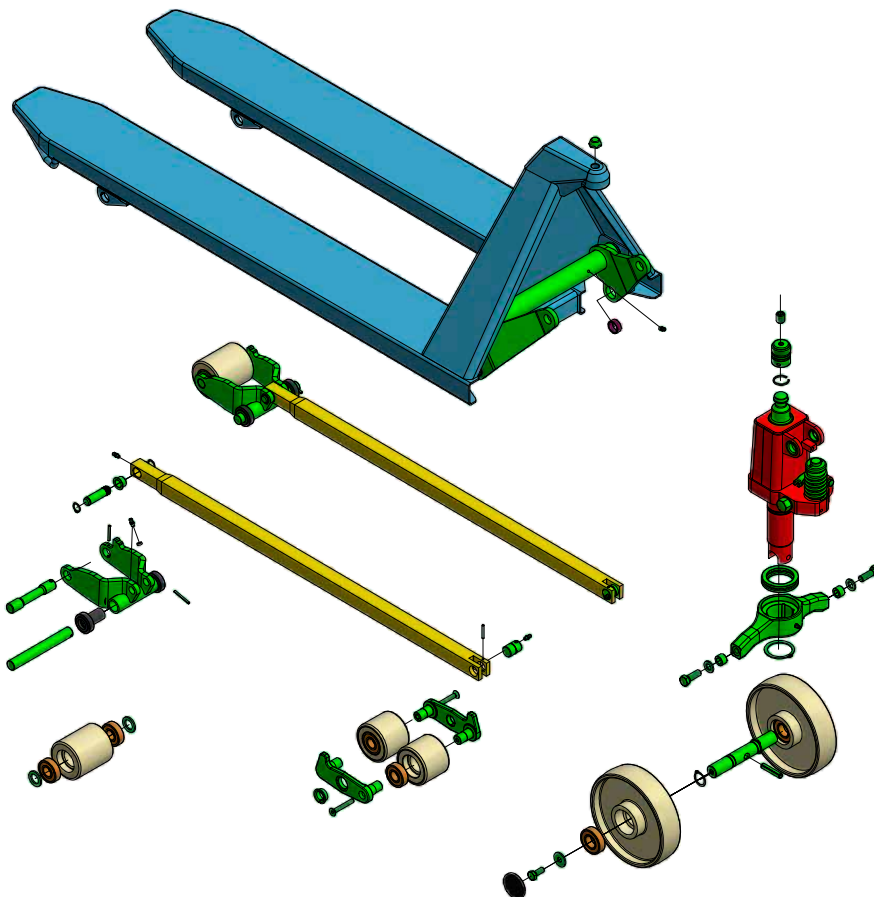



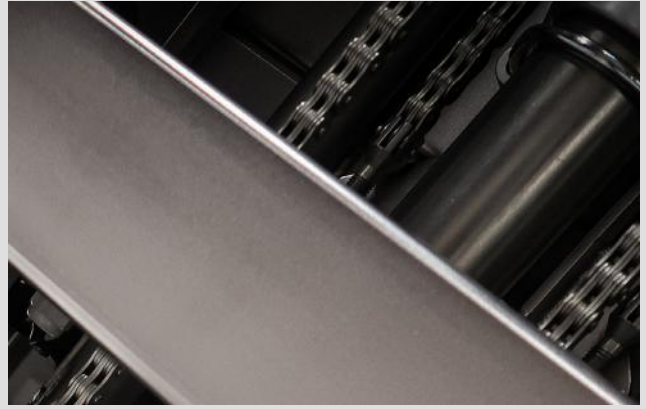

## **Ergonomic Lifting Equipment**

**Logitrans A/S**

+45 76 88 16 00

info@logitrans.com

www.logitrans.com

