

PNEUMATIC STACKER Lift & Roll[®]



« Ergonomic : Keeps load at working height preventing back strains »



Ideal
Lean
Manufacturing

Steel or
Stainless steel IP65

 www.actiwork.fr



Actiwork
Feel well at work

PNEUMATIC STACKER LIFT & ROLL®

Innovation Actiwork :

THE BENEFITS

Pneumatic lift for keeping boxes , parcels or crates on wheels at working height, used in lean manufacturing environment.

- Ergonomics, reduces MSD risks TMS and absenteeism
- Base and forks can be adapted to any application
- Automatic load leveling using photoelectric cell sensors
- Available in IP65 and stainless steel.
- Compact module, stroke 900mm

Front model
CL52D100 C

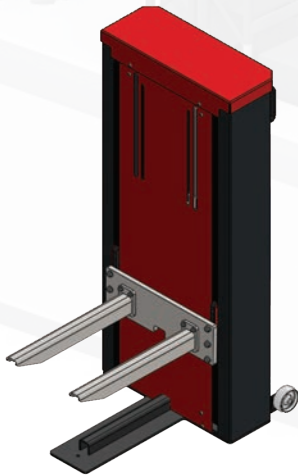

Left side model
CL52D300 C

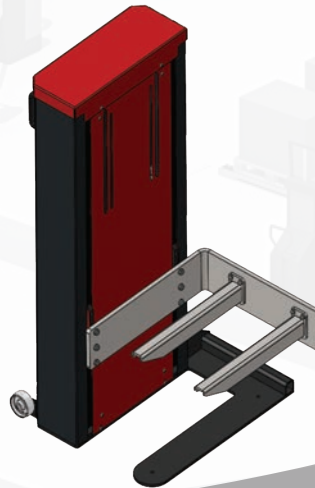

Right side model
CL52D510 C

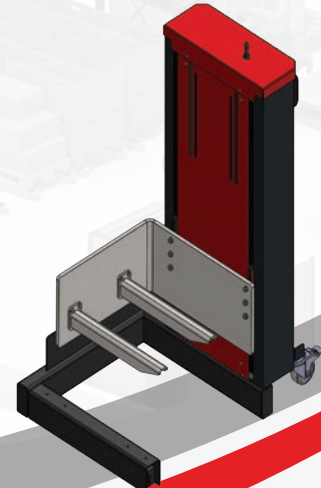

TECHNICAL DESCRIPTION :

- The pneumatic stracker lift and roll is designed for levelling rolling base also called ROLLS, 600 x 400 mm (Other sizes on request).
- Robust construction in painted steel with pulley guides for forks
- Fitted with a pneumatic cylinder for a lifting height of 920 mm
- Nominal capacity of 200 kg uniformly spread on the forks
- Lifting speed of 1 - 10 m/min using compressed air supply at 6 bar
- Dimensions (without forks) (L x W X H) : 520 x 240 x 1350 mm
- Weight : 125 kg
- Up/Down control box (optionnal: coiled cable)
- Can be configured to load from the front as well as both left and right sides. Static version can be fixed to the ground. Or a semi mobile version has braked swivel castors for easy moving

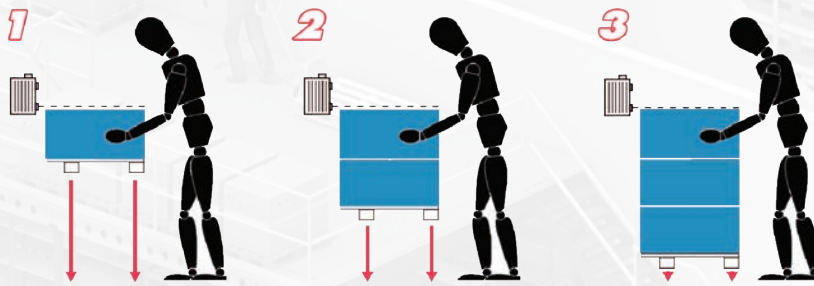

CONSTANT LEVEL OPTION

New automatic constant level system. The ideal solution for stacking or de-stacking boxes automatically.

- Remotely controlled height through photoelectric cell
- 2 modes of operation
 - **Automatic:** For stacking and de-stacking
 - **Manual** using Up/Down control box

DIFFERENT CONFIGURATIONS TO FIT THE WORKPLACE

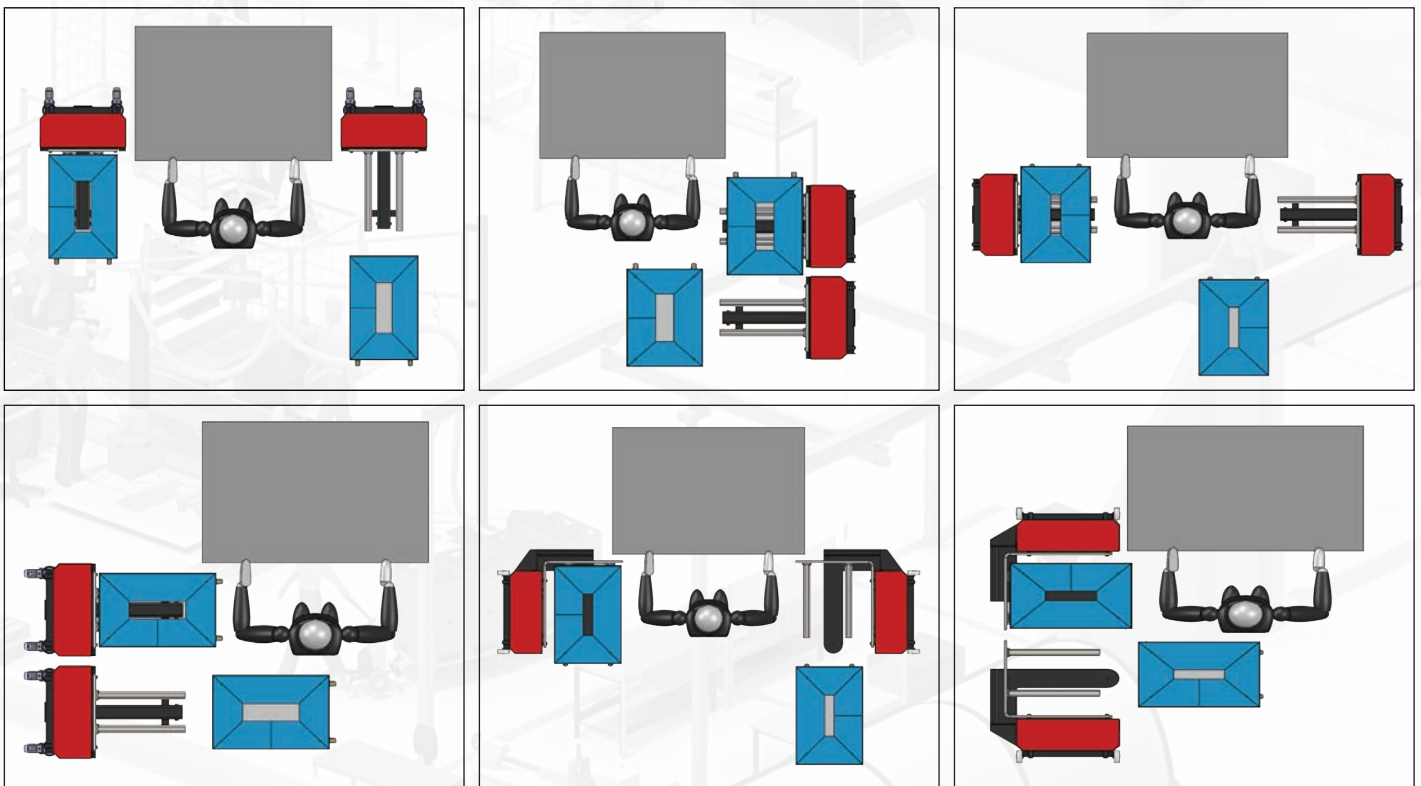

Others on request

MANUAL MODELS (JOYSTICK)

Load	Model	Steel*	Stainless steel
Front	Static	CL52D100 C	CL52E100 B
Front	Mobile	CL52D400 C	CL52E100 B
Right side	Static	CL52D200 C	CL52E100 B
Right side	Mobile	CL52D500 C	CL52E100 B
Left side	Static	CL52D300 C	CL52E100 B
Left side	Mobile	CL52D600 C	CL52E100 B

AUTOMATIC CONSTANT LEVEL MODELS

Model	Load	Steel*	Stainless steel
Front	Static	CL52D110 C	CL52E110 B
Front	Mobile	CL52D410 C	CL52E410 B
Right side	Static	CL52D210 C	CL52E210 B
Right side	Mobile	CL52D510 C	CL52E510 B
Left side	Static	CL52D310 C	CL52E310 B
Left side	Mobile	CL52D610 C	CL52E610 B

* All models are also available in stainless steel

THE PNEUMATIC LIFT STACKER & ROLL® IN PICTURES



Painted steel version



The most compact stacker (240mm depth)



Control box with NC option



THEY TRUST US



OFFICES AND WORKSHOPS

260 RUE DES BARRONNIÈRES

01700 - BEYNOST

Tél : 04.72.01.50.60

Fax : 04.78.88.39.01

Courriel : aw.ergo@actiwork.fr



Visit our website : www.actiwork.fr